

V O L V O



Volvo Wheel Loaders 11.0-17.3 t 167-186 hp

L60H

Volvo Construction Equipment

L60H

Leave the heavy-duty work for the L60H, designed to do more, be more comfortable and help you increase your productivity.



Designed to do more

Hard work has never felt so easy. H-Series wheel loaders are built with an industry-leading, strong frame, which, combined with the ideally-matched genuine Volvo drivetrain, achieves long-lasting performance. And with the help of a range of smart apps you can boost the efficiency of your operation from the comfort of the cab.



Loaded with versatility

- Torque Parallel linkage
- Volvo attachment bracket
- Range of purpose-built attachments
- Rehandling bucket
- 3rd and 4th hydraulic functions



Keep it moving

- Quick hydraulic oil fill thanks to new mounted nipple
- Improved cooling capacity
- Strong frame and central hinge
- Optional delayed engine shutdown



Safety as standard

- Anti-slip steps and strategically placed handrails
- Orange seatbelt
- Redesigned side mirrors
- Rear-view camera



Strong and stable

- Optimized loading unit weight, heavyduty counterweight for greater stability
- Standard electro-servo controls
- Bucket leveling function



Increased productivity

- Optional lock-up converter
- Rimpull control
- Smart Control
- Smooth Control
- Eco pedal



Greater access

- Cooler installation slides out for easier cleaning
- Repositioned fill spouts for transmission and engine oil
- Ground-level access to service points
- Electronically-operated engine hood

Volvo L60H in detail

Engine

6-cylinder, 6 liters inline turbocharged diesel engine with an advanced fuel injection system with the common rail. Fuel is distributed under high pressure from a high-pressure accumulator, the rail. One belt driven high pressure pump deliver the fuel to the rail and then further on via high-pressure pipes to the electronically operated fuel injectors. Engine meets Stage V emission legislation.

Engine	Volvo	D6J
Max. power at	r/min	1 500 - 1 800
ISO 14396 gross	kW	122
	hp	166
ISO 9249, SAE J1349 net	kW	122
	hp	166
Max. torque at	r/min	1 400
ISO 14396 gross	Nm	820
ISO 9249, SAE J1349 net	Nm	820
Economic working range	r/min	800 - 1 600
Displacement	l	5.7

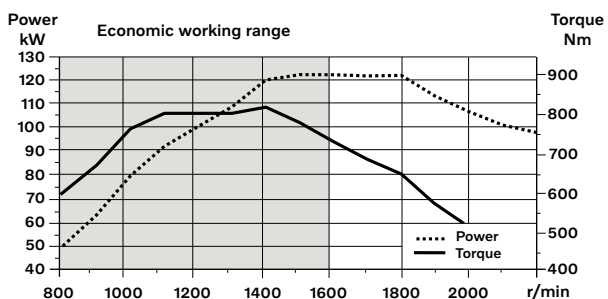

Electrical System

Contronic electrical system with central warning light and buzzer for following functions: - Serious engine fault, Low steering system pressure, Over speed warning engine, Interruption in communication (computer fault), Central warning light and buzzer with the gear engaged for the following functions: Low engine oil pressure, High engine oil temperature, High charge air temperature, Low coolant level, High coolant temperature, High crank case pressure, Low transmission oil pressure, High transmission oil temperature, Low brake pressure, Engaged parking brake, Fault on brake charging, Low hydraulic oil level, High hydraulic oil temperature, Overspeeding in engaged gear, High brake cooling oil temperature front and rear axles, etc.

Batteries	V	2 x 12
Battery capacity	Ah	2 x 110
Cold cranking capacity, approx	A	680
Alternator rating	W/A	3 135/80
Starter motor output	kW	55

Brake system

Service brake: Volvo dual-circuit system with outboard mounted, hydraulically operated, fully sealed and circulating oil cooled wet disc brakes. Four operator selectable transmission disengagement settings while braking.

Parking brake: Dry disc brake mounted on the transmission output shaft. Applied by spring force, electro-hydraulically released with a switch on the instrument panel.

Secondary brake: Dual brake circuits with rechargeable accumulators.

Standard: The brake system complies with the requirements of ISO 3450, 71/320/EEC

Number of brake discs per wheel		1
Accumulators	l	3 x 0.5
Accumulators for parking brake	l	1 x 0.5

Lift Arm System

Torque parallel linkage (TP-linkage) with high breakout torque and parallel lift-arm action.

Lift cylinders		2
Cylinder bore	mm	110
Piston rod diameter	mm	70
Stroke	mm	665
Tilt cylinder		1
Cylinder bore	mm	150
Piston rod diameter	mm	80
Stroke	mm	444

Steering System

System supply: The steering system has priority feed from a load-sensing axial piston pump with variable displacement.

Steering cylinders: Two double-acting cylinders.

Steering cylinders		2
Cylinder bore	mm	70
Rod diameter	mm	45
Stroke	mm	386
Working pressure	MPa	21
Maximum flow	l/min	60
Maximum articulation	± °	40

Cab

Instrumentation: All important information is centrally located in the operator's field of vision. Display for Contronic monitoring system.

Heater and defroster: Heater coil with filtered fresh air and fan with auto and 11 manual speed settings. Defroster vents for all window areas.

Operator's seat: Operator's seat with adjustable air suspension and retractable seatbelt. The seat is mounted on a bracket on the rear cab wall and floor. The forces from the retractable seatbelt are absorbed by the seat rails.

Standards: The cab is tested and approved according to ROPS (ISO 3471), FOPS (ISO 3449). The cab meets with requirements according to ISO 6055 (Operator overhead protection - Industrial trucks) and SAE J386 (Operator Restraint System).

Emergency exit: Use emergency hammer to break window

Ventilation	m ³ /min	9
Heating capacity	kW	16
Air conditioning (optional)	kW	75

Sound Level

Sound pressure level in cab according to ISO 6396		
L _{pA}	dB	68
External sound level according to ISO 6395 and EU Noise Directive 2000/14/EC		
L _{WA}	dB	104

Service Refill

Service accessibility: Large, electrically operated easy-to-open hood covering whole engine compartment. Fluid filters and component breather air filters are located from ground level access and promote long service intervals. Machine contronics have possibility to monitor, log and analyze data to facilitate troubleshooting. A quick-fit adapter on the hydraulic tank provides faster hydraulic oil fill.

Fuel tank	l	222
DEF/AdBlue® tank	l	20
Engine coolant	l	30
Hydraulic oil tank	l	90
Transmission oil (non lock-up)	l	21
Transmission oil (lock-up)	l	22
Engine oil	l	20
Axle oil front	l	25
Axle oil rear	l	25

Hydraulic system

Closed center load sensing hydraulic system with non pressurised hydraulic tank and pilot operated control valves.

System supply: Variable displacement axial piston pump supply the hydraulic system.

Valves: The central valve distributes pressure and flow out to the cooling fan, steering, brake, pilot and hydraulic system. Steering system gets priority over others.

Lift function: The valve has four positions; raise, hold, lower and float position. Automatic boom kickout position can be set to any position between maximum reach and full lifting height.

Tilt function: The valve has three functions; rollback, hold and dump. Automatic tilt out/tilt in can be adjusted to the desired bucket angle.

Cylinders: Double-acting cylinders for all functions.

Filter: Full flow filtration through 10 micron (absolute) filter cartridge.

Working pressure maximum, pump 2 for steering-, brake-, pilot- and working hydraulic system	MPa	26
Flow at engine speed	l/min	145
	MPa	10
	r/min	1900
Working pressure maximum, pump 3 for brake- and cooling fan system	MPa	21
Flow at engine speed	l/min	33
	MPa	10
	r/min	1900
Pilot system, working pressure	MPa	3.5
Cycle times		
Lift	s	5.4
Tilt	s	1.9
Lower, empty	s	2.7
Total cycle time	s	10

Drivetrain

Torque converter: Single-stage

Transmission: Volvo countershaft transmission with single lever control. Fast and smooth shifting of gears with Pulse Width Modulation (PWM) valve.

Transmission: Volvo Automatic Power Shift (APS) gear shifting system with fully automatic shifting 1-4 and mode selector with 4 different gear shifting programs, including AUTO mode. Also equipped with Rimpull control to avoid wheel spin and optimize bucket filling.

Axles: Volvo fully floating axle shafts with planetary hub reductions and cast steel axle housing. Fixed front axle and oscillating rear axle. 100% differential lock on the front axle.

Transmission	Volvo:	HTE 125C Non Lock-up / HTE 125 Lock-up
Torque multiplication, stall ratio		2.5:1 Non Lock-up / 2.59:1 Lock-up
Maximum speed		
1st gear	km/h	Converter 7.5 / Lock-up 7.5
2nd gear	km/h	Converter 15 / Lock-up 15
3rd gear	km/h	Converter 28 / Lock-up 29
4th gear	km/h	Converter 46 / Lock-up 50
4th gear: Shown in speedometer and limited by ECU		
Measured with tires		20.5R25
Front axle/rear axle		AWB 15/AWB 15
Rear axle oscillation	± °	13
Ground clearance at oscillation	mm	470
	°	13



Specifications

Tires 20.5 R25 L3

		L60H	
		Standard boom	Long boom
B	mm	6 010	6 520
C	mm	3 000	3 000
D	mm	440	430
F	mm	3 270	3 270
G	mm	2 133	2 134
J	mm	3 550	4 080
K	mm	3 870	4 380
O	°	56	56
P _{max}	°	45	42
R	°	43	45
R ₁ *	°	46	50
S	°	79	79
T	mm	123	150
U	mm	410	590
X	mm	1 900	1 900
Y	mm	2 430	2 430
Z	mm	3 210	3 590
a ₂	mm	5 340	5 340
a ₃	mm	2 900	2 900
a ₄	±°	40	40

* Carry position SAE

**Calculated with additional protective guarding

Where applicable, specifications and dimensions are according to ISO 7131, SAE J732, ISO 7546, SAE J742, ISO 14397, SAE J818

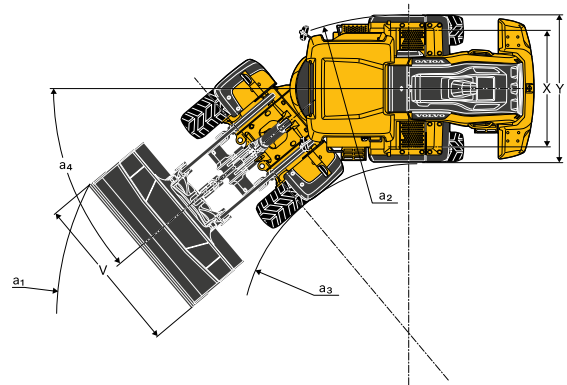
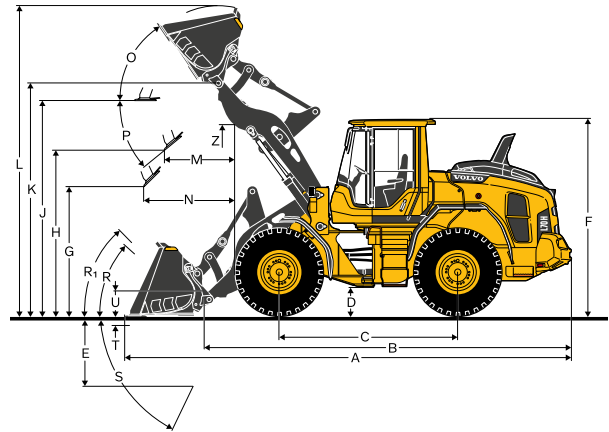

Tires: 20.5R25 L3

		L60H
SAE-Load	kg	3 450
Operating weight without load*	kg	12 883
Grapple sales code		82 194
A	m ²	1.3
B	mm	3 412
C	mm	1 483
D	mm	2 929
E	mm	1 175
F	mm	1 532
G	mm	2 350
H	mm	4 333
I	mm	5 878
J	mm	1 997
K	mm	2 080
L	mm	1 709
M	mm	7 861

* Calculated with additional protective guarding

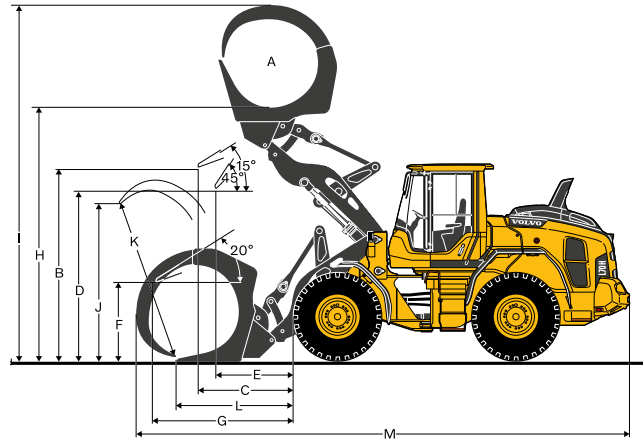

Tires: 20.5R25 L3		
		L60H
Material handling arm sales code		92007
A*	kg	1 800
B*	kg	1 400
C*	kg	1 150
Static tipping load, straight		3 238
35deg. Turn	kg	2 910
at full turn	kg	2 814
D	mm	2 592
E	mm	2 002
F	mm	1 465
G	mm	3 270
H	mm	4 305
I	mm	5 439
J	mm	905
K	mm	1 227
L	mm	1 580
M	mm	2 258
N	mm	3 241
O	mm	4 319
P	mm	1 512
Q	mm	5 286
R	mm	6 171
S	mm	7 139
Operating weight without load	kg	11 885

* Op. load at full turn + tipping position

Tipping loads calculated for max. arm length

**Calculated with additional protective guarding

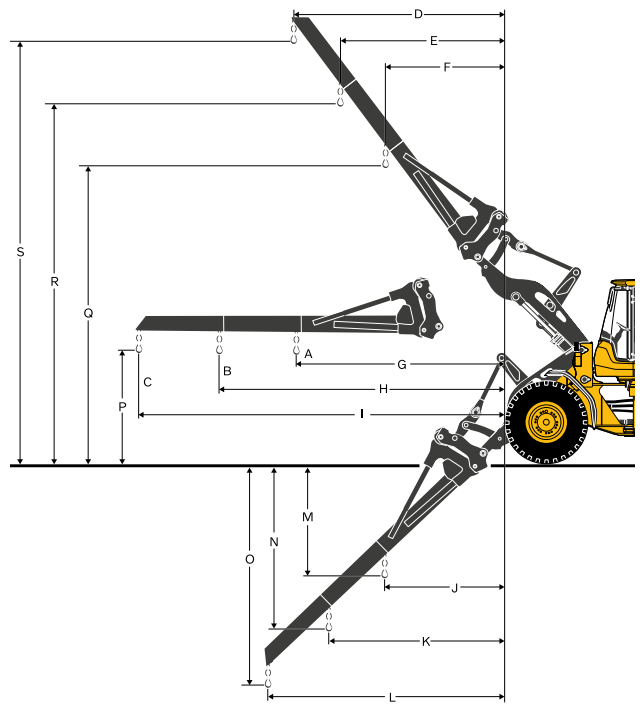

Tires: 20.5R25 L3		
		L60H
Fork frame sales code		83768
Fork tines sales code (R/L)		80042/80043
Static tipping load, straight	kg	6 930
35deg. Turn	kg	6 230
at full turn	kg	6 024
at load center distance*	mm	600
A	mm	798
B	mm	1 567
C	mm	-38
D	mm	1 831
E	mm	3 713
F	mm	700
Operating weight without load	kg	11 965





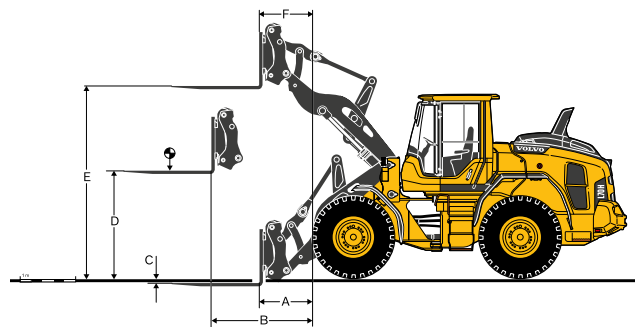





* Firm and level ground

**Calculated with additional protective guarding



Specifications

L60H*

BR 20,5R25 VJT L3	GENERAL PURPOSE						GRADING	LIGHT MATERIAL		LONG BOOM	
											
	1.8 m³ STE H T	1.9 m³ STE H BOE	2.1 m³ STE P BOE	2.1 m³ STE H BOE	2.3 m³ STE P BOE	2.3 m³ STE H BOE	1.7 m³ GRB H BOE	3.1 m³ LM H	5 m³ LM H	2.3 m³ STE P BOE	
Volume, heaped ISO/SAE	m³	1.8	1.9	2.1	2.1	2.3	2.3	1.7	3.1	5.0	2.3
Volume at 110% fill factor	m³	2.0	2.1	2.3	2.3	2.5	2.5	1.9	3.4	5.5	2.5
Static tipping load, straight	kg	9 020	8 860	9 270	8 760	9 190	8 650	7 750	8 460	8 470	-1820
at 35° turn	kg	8 080	7 930	8 320	7 830	8 240	7 730	6 930	7 550	7 520	-1 680
at full turn	kg	7 800	7 650	8 040	7 560	7 960	7 460	6 690	7 280	7 250	-1 640
Breakout force	kN	84.9	80.2	83	76.1	79.0	72.8	60.2	61.7	53.8	+8.0
A	mm	7 410	7 340	7 300	7 400	7 370	7 470	7 650	7 680	7 910	+520
E	mm	1 190	1 140	1 110	1 200	1 160	1 260	1 400	1 480	1 700	+50
H	mm	2 750	2 800	2 820	2 760	2 780	2 720	2 510	2 580	2 430	+550
L	mm	5 110	5 110	5 120	5 170	5 190	5 240	4 530	5 280	5 480	+510
M	mm	1 070	1 050	1 020	1 090	1 060	1 140	1 130	1 320	1 500	+20
N	mm	1 580	1 590	1 570	1 610	1 590	1 630	1 490	1 630	1 670	+450
V	mm	2 500	2 500	2 500	2 500	2 500	2 500	2 500	2 550	2 650	0
a ₁ clearance circle	mm	11 800	11 760	11 760	11 800	11 800	11 840	12 140	12 010	12 240	+480
Operating weight	kg	12 260	12 320	12 120	12 360	12 160	12 400	12 260	12 450	12 740	+230

*Calculated with additional protective guarding.

Bucket Selection Chart

The chosen bucket is determined by the density of the material and the expected bucket fill factor. The actual bucket volume is often larger than the rated capacity, due to the features of the TP linkage, including an open bucket design, good rollback angles in all positions and good bucket filling performance. The example represents a standard boom configuration. Example: Sand and gravel. Fill factor ~ 105%. Density 1.65 t/m³. Result: The 1.9 m³ bucket carries 2.0 m³. For optimal stability always consult the bucket selection chart.

Material	Bucket fill, %	Material density, t/m³	ISO/SAE bucket volume, m³	Actual volume, m³
Earth/Clay	~ 110	~ 1.55	1.9	2.1
		~ 1.4	2.1	2.3
		~ 1.3	2.3	2.5
Sand/Gravel	~ 105	~ 1.65	1.9	2.0
		~ 1.5	2.1	2.2
		~ 1.35	2.3	2.1
Aggregate	~ 100	~ 1.75	1.9	1.9
		~ 1.55	2.1	2.1
		~ 1.55	2.3	2.3
Rock	≤100	~ 1.7	1.7	1.7

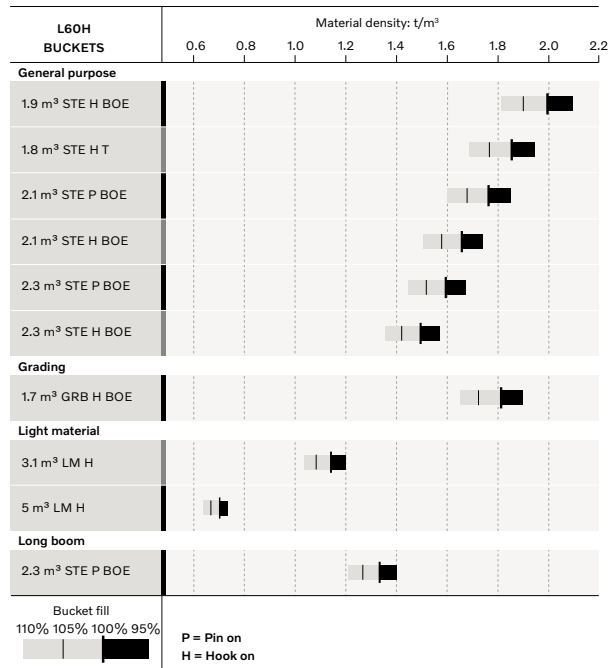

How to read bucket fill factor

Supplemental Operating Data

Tires 20.5 R25 L3	Standard boom			Long boom	
	17.5 R25 L2	20.5 R25 L2	600/65 R25 L3	600/65 R25 L3	
Width over tires	mm	-130	+8	+96	+96
Ground clearance	mm	-68	-10	-30	-22
Tipping load, full turn	kg	-337	-166	-72	0
Operating weight	kg	-544	-112	+8	+3

Calculated with 2.3 m³ STE P BOE, additional protective guarding

Equipment

STANDARD EQUIPMENT

Engine

Exhaust after-treatment system
 3-stage air cleaner, pre-cleaner, primary and secondary filter
 Indicator glass for coolant level
 Preheating of induction air
 Fuel pre-filter with water trap
 Fuel filter
 Crank case breather oil trap
 Exhaust heat ventilation

Tires

17.5R25
 20.5R25
 600/65R25

Drivetrain

Automatic Power Shift
 Fully automatic gear shifting, 1-4
 PWM-controlled gear shifting
 Forward and reverse switch by hydraulic lever console
 Rimpull control
 Indicator glass for transmission oil level
 Differentials: Front, 100% hydraulic diff lock. Rear, conventional

Electrical System

24 V, pre-wired for optional accessories
 Alternator 80A/3135W
 Battery disconnect switch
 Maintenance-free batteries
 Battery box, steel
 Fuel gauge
 Electric horn
 Instrument cluster:
 Fuel level
 Diesel Exhaust Fluid/AdBlue level
 Transmission temperature
 Coolant temperature
 Instrument lighting
 Lighting:
 Twin halogen front headlights with high and low beams
 Parking lights
 Double brake and tail lights
 Turn signals with flashing hazard light function
 Halogen work lights (2 front and 2 rear)

STANDARD EQUIPMENT

Contronic monitoring system

Contronic display
 Fuel consumption
 Ambient temperature
 Clock
 Test function for warning and indicator lights
 Brake test
 Warning and indicator lights:
 Battery charging
 Parking brake
 Warning and display message:
 Regeneration
 Engine coolant temperature
 Charge air temperature
 Engine oil temperature
 Engine oil pressure
 Transmission oil temperature
 Transmission oil pressure
 Hydraulic oil temperature
 Brake pressure
 Parking brake applied
 Brake charging
 Overspeed at direction change
 Axle oil temperature
 Steering pressure
 Crank case pressure
 Attachment lock open
 Level warnings:
 Fuel level
 Diesel Exhaust Fluid/AdBlue level
 Engine coolant level
 Transmission oil level
 Hydraulic oil level
 Washer fluid level
 Engine torque reduction in case of malfunction indication:
 High engine coolant temperature
 High engine oil temperature
 Low engine oil pressure
 High crank case pressure
 High charge air temperature
 Engine shutdown to idle in case of malfunction indication:
 High transmission oil temperature
 Slip in transmission clutches
 Key pad, background lit
 Start interlock when gear is engaged

Hydraulic system

Main valve, double acting 2-spool with hydraulic pilots
 Variable displacement axial piston pumps (2) for:
 Working hydraulics, pilot hydraulics, steering system, brakes
 Cooling fan, brakes
 Hydraulic control levers
 Mechanical hydraulic lever lock
 Automatic boom kick-out
 Automatic bucket positioner
 Double acting hydraulic cylinders
 Indicator glass for hydraulic oil level
 Hydraulic oil cooler

Brake system

Dual brake circuits
 Dual brake pedals
 Secondary brake system
 Parking brake, electrical-hydraulic
 Brake wear indicators
 Outboard mounted circulating oil cooled wet disc brakes on all four wheels

Equipment

STANDARD EQUIPMENT

Cab

ROPS (ISO 3471), FOPS (ISO 3449)
 Single key kit door/start
 Acoustic inner lining
 Cigarette lighter, 24 V power outlet
 Lockable door
 Cab heating with fresh air inlet and defroster
 Fresh air inlet with two filters
 Automatic heat control
 Floor mat
 Dual interior lights
 Interior rearview mirrors
 Dual exterior rearview mirrors
 Sliding window, right side
 Tinted safety glass
 Retractable seatbelt (SAE J386)
 Adjustable steering wheel
 Storage compartment
 Document pocket
 Sun visor
 Beverage holder
 Windshield washer front and rear
 Windshield wipers front and rear
 Interval function for front and rear wipers
 Foot step, left side (toolbox lockable included)

Service and maintenance

Engine oil remote drain and fill
 Transmission oil remote drain and fill
 Sliding hydraulic oil cooler and AC-condenser
 Lubrication manifolds, ground accessible
 Pressure test ports: transmission and hydraulic, quick connects
 Service platforms with anti-slip surfaces
 Quick-fit hydraulic oil fill
 CareTrack
 Telematics, 6 -year subscription
 Toolbox, lockable

External equipment

Basic fenders, front and rear
 Viscous cab mounts
 Rubber engine and transmission mounts
 Engine hood, electronically openable
 Frame, joint lock
 Vandalism lock for engine compartment
 Lifting eyes
 Tie down eyes
 Tow hitch
 Counterweight, pre-drilled for optional guards

OPTIONAL EQUIPMENT

Engine

Air pre-cleaner, cyclone type
 Air pre-cleaner, oil-bath type
 Air pre-cleaner, turbo type
 Engine auto shut down
 Engine block heater, 120V / 230V
 Fuel heater
 Fuel fill strainer
 Hand throttle control
 Max. fan speed, hot climate
 Reversible cooling fan

Drivetrain

Lock-up torque converter
 Rear axle with limited slip
 Speed limiter, 20 km/h
 Speed limiter, 30 km/h
 Speed limiter, 40 km/h

OPTIONAL EQUIPMENT

Hydraulic system

Arctic kit: Attachment locking, pilot hoses and hydraulic oil
 Attachment bracket, cast, visibility-optimized
 Attachment bracket, side-tilting
 Separate attachment locking, long boom
 Separate attachment locking, standard boom
 Single acting lifting function
 Boom suspension system
 Hydraulic fluid, biodegradable, Volvo
 Hydraulic fluid, fire resistant
 Hydraulic fluid, for hot climate
 Detent for 3rd hydraulic function
 Adjustable flow for 3rd hydraulic function
 Hydraulic, 2 functions Electro-servo, std/long boom
 Hydraulic, 3 functions Electro-servo, std/long boom
 Hydraulic, 4 functions Electro-servo, std/long boom
 Single lever control, 2 funct Electro-servo, std/long boom
 Single lever control, 3 funct Electro-servo, std/long boom
 Single lever control, 4 funct Electro-servo, std/long boom

Brake system

Parking brake alarm, audible

Cab

ACC control panel, with Fahrenheit scale
 Anchorage for Operator's manual
 Asbestos dust protection filter
 Automatic Climate Control, ACC
 Automatic Climate Control, ACC, corrosion protection condenser
 Cab air pre-cleaner, cyclone type
 Carbon filter - cab
 Remote door opener
 Lunch box holder
 Operator's seat, Volvo air-suspended, heavy-duty, high back, heated
 Operator's seat, Volvo air-susp, 3-point seatbelt
 Operator's seat, ISRI, heated, high back
 Operator's seat, Premium Comfort ISRI
 Operator's seat, Premium Comfort ISRI 3-point seat belt
 Armrest, operator's seat, ISRI, left only
 Armrest, operator's seat, Volvo, left
 Safety belt, 3" (75mm) width
 Safety belt warning
 Radio installation kit including 12 volt outlet, left-side
 Radio installation kit including 12 volt outlet, right-side
 Radio installation kit, 12V, for USA
 Radio with AUX, Bluetooth and USB connection
 DAB Radio
 Subwoofer
 Forward view mirror
 Rear view mirrors, el.adjusted and heated
 Rear view mirrors, long arm right
 Rear view mirrors, el.adjusted and heated, long arm right
 Steering wheel knob
 Sun blinds, rear windows
 Sun blinds, side windows
 Timer cab heating
 Universal door/ignition key
 Window, sliding, door
 Cab, Hot applications. Roof, steel
 Fire extinguisher cab
 Outside steel protection cab
 Rear view mirrors long arm, cab
 Reinforced windshield, flat

Service and maintenance

Automatic lubrication system
 Automatic lubrication system for long boom
 Oil sampling valve
 Refill pump for automatic lubrication system
 Tool kit
 Wheel nut wrench kit

OPTIONAL EQUIPMENT

Electrical

Battery disconnect switch, additional in cab
Anti-theft device
Headlights, assym. left
Headlights, assym. right LED
Headlights, assym. left LED
Emergency stop
License plate holder, lighting
Reduced function working lights when reverse gear activated
Side marker lamps
Forward camera, colour
Rear view camera including monitor, colour
Rear view mirrors, long arm, right side
Rearview mirrors, adjustable, el. heated
Reverse alarm
Reverse lights
Reversing warning light
Warning beacon (flasher), LED automatic
Warning beacon (flasher), LED
Seatbelt indicator, external
Working lights, attachments, 1 LED
Warning beacon LED
Warning beacon LED automatic
LED Head Light
LED tail light
LED working lights, attachments
LED working lights on cab, front and rear
LED working lights on cab, front, 2 alt. 4 LED lamps
LED working lights on cab, rear, 2 alt. 4 LED lamps
LED working lights, rear in grille, 2 LED lamps
LED working lights, front above head lamps, 2 LED lamps
LED work lights, side on cab, 4 LED lamps
LED light packages
Working lights halogen, attachments
Working lights on cab halogen, front and rear
Working lights on cab halogen, rear
Co Pilot available
Rearview camera in Co pilot
Max Boom height
Can Bus Interface
Delayed Engine Shutdown

Protective equipment

Anti-theft device
Bellyguard front
Bellyguard rear
Boom cylinder hose and tube guards
Cab roof, heavy duty
Center hinge and rear frame guard
Corrosion protection, painting of machine
Cover plate front frame, heavy-duty
Cover plate, under cab
Cover plates rear frame
Guards for front headlights
Guards for radiator grill
Guards for tail lights, heavy-duty
Wheel/axle seal guards
Window guards, side and rear
Windshield guard

OPTIONAL EQUIPMENT

External equipment

Deleted front mudguards
Fire extinguisher
Bracket for fire extinguisher
Fire suppression system
Mudguards, full cover, rear for 80-series tires
Mudflap kit for mudguards, full cover for 80-series tires
Mudguards, full cover, rear and front/rear for 65-series tires
Mudflap kit for mudguards, full cover for 65-series tires
Footsteps front frame
Footsteps, right-hand side
Flexible rear step
Cab ladder, rubber suspended

Other equipment

CareTrack, GSM/Satellite
CE-marking
Comfort Drive Control (CDC) Electro-servo
Secondary steering
Counterweight, logging
Counterweight, signal painted, chevrons
Option for machines without dinitrol
Noise reduction kit, EU excluding decal
Sign, 50 km/h
Sign, slow moving vehicle

Tires and Rims

17.5R25
20.5R25
600/65R25
620/75R26 Agriculture application only
750/65R26 Agriculture application only

Attachments

Buckets:
Straight
Spade nose
High tipping
Light material
Grading
Wear parts:
Bolt-on edge
Bolt-on or weld-on bucket teeth
Segments
Log grapples
Fork equipment
Material handling arm
Snow blade
Broom
Sand spreading bucket
Bale clamp
Drum rotator



BIG ENOUGH TO TRUST SMALL ENOUGH TO CARE

Founded in 1974...



CJD Equipment are in the industry for the long term and have the skills and knowledge to support you and your equipment. CJD Equipment takes great pride in being Volvo CE's first and only authorised partner in Australia for three decades. Together, we provide a full range of machinery ideally suited to Australia's unique landscapes and industry requirements. These products are fully supported through a nationwide network of branches, and carefully selected dealers and service agents, strategically positioned to ensure total support.

With fully equipped parts warehouses in every capital city, and dealers throughout major regional towns, we have the support network in place to ensure you're well supported, no matter where you or your machines are. Ongoing in-house training programs ensures our technicians' skills keep pace with the latest technology and product advances.

Visit www.cjd.com.au to read more about our history, range of products and to locate your local branch or dealer.

Head Office
54 Great Eastern Highway
South Guildford, WA 6055

Visit www.cjd.com.au
Call 1300 139 804
Email enquiries@cjd.com.au

 [Facebook.com/cjdequipment](https://www.facebook.com/cjdequipment)
 [Linkedin.com/company/cjd-equipment](https://www.linkedin.com/company/cjd-equipment)
 [Instagram.com/cjd_equipment](https://www.instagram.com/cjd_equipment)

