

**T410
SAR**



**THE BEST
IN THE BUSINESS**



AUSTRALIAN MADE. WORLD'S BEST.



T410 SAR

VERSATILITY AT ITS BEST

THE WAIT IS OVER – THE NEW T410SAR IS HERE. OFFERING BETTER WEIGHT DISTRIBUTION WITH ITS SET-FORWARD FRONT AXLE AND CLASSIC KENWORTH STYLING, THE T410SAR DELIVERS BIGGER PAYLOADS, ENHANCED SAFETY, A SUPERIOR DRIVER ENVIRONMENT, IMPROVED FUEL ECONOMY AND A GREATER CHOICE OF OPTIONS. THE NEW T410SAR – READY WHEN YOU ARE!

Featuring the classic Kenworth flat grille, the T410SAR offers a shorter bumper-to-back-of-cab (BBC) length and has been specifically designed to provide for maximum payload under Australian regulations for 19m B-Double, most 19m Quad Dog applications and car carrier specifications.

Available in rigid, single and multi-trailer configurations with your choice of day and sleeper cabs, the T410SAR is as versatile as it is strong. Rated at up to 70 tonnes GCM, it is ideal for local and interstate distribution, as well as Performance Based Standards operators and other heavy duty applications. Built to last the distance, the durable T410SAR sets the benchmark for whole of life value.

Powered by a 460 hp or 510 hp PACCAR MX-13 engine, the new T410SAR offers the smooth and intuitive shift strategies of PACCAR's 12-speed automated transmission. Equally focused on durability, the powertrain incorporates improved engine cooling and simplified electrical architecture, plus improved service access to key systems. The T410SAR also comes with a selection of optional Eaton manual and automated manual transmissions.

Ergonomically designed, the spacious 2.1-metre wide cab offers a range of benefits for the driver and has been equipped with an intuitive layout, allowing drivers to maintain concentration and reduce fatigue. The T410SAR interior offers a driver experience unmatched for comfort and control in its class.

Combining the best attributes of both a cab-over and conventional truck, the T410SAR offers excellent maneuverability and visibility and like a cab-over, a minimal overall length, with the serviceability, ease of cab access and low-tare weight of a bonneted truck.

Delivering the power and stability to handle higher payloads over longer distances, the T410SAR is the best on-road solution for your transport needs.



SOFT TRIM - PREMIUM INTERIOR

Natural Sand

Tan Saddle

Grey Graphite

Red Garnet

Brown Umber

Blue Indigo

SOFT TRIM - FLEET SPEC INTERIOR

Kenworth Black

HARD TRIM INTERIOR

Charcoal



**THE
BEST**

PREMIUM INTERIOR

FLEET SPEC INTERIOR

DRIVER EXPERIENCE

DESIGNED FROM THE INSIDE OUT, THE T410SAR CABIN IS CENTRED COMPLETELY AROUND THE NEEDS OF THE DRIVER.

The T410SAR's wide cab offers increased walkthrough space between seats, greater head-to-toe room for the driver, and more standing room in the sleeper cabs, the interior feels more open, more relaxed and is far easier to move around in. There's also greater storage – all of it positioned for maximum convenience and reach.

Driver comfort is further enhanced by an advanced heating and air-conditioning system with automatic climate control. More powerful yet more efficient, it maintains optimum cabin temperature at all times, in all driving conditions, all year round.

The T410SAR cabin also boasts triple sealed doors and door apertures—an innovation that minimises noise and dust leaks, and whose quality construction you'll feel and hear, each time the doors close.

Behind the wheel you immediately feel in command. The cabin's superior ergonomics mean switchgear and controls are positioned intuitively, and that dashboard instrumentation and electronic screens are visible at a glance.

Equipping your T410SAR with a PACCAR or Eaton automated transmission sharpens the driver's focus even more. Operated via a steering column mounted stalk, the transmission controller enables the driver to select various gears and control engine braking from one convenient location. This frees up room on the dashboard and in the cabin, enabling greater freedom of movement.

Designed with fleets in mind, the T410SAR offers a new, work-ready, easy-to-clean interior. Or opt for the traditional trim with Kenworth's signature 'soft plush' studded pattern in your choice of six colours.



THE BEST APPROACH TO SAFETY

EVERY KENWORTH OFFERS A CORE SAFETY FEATURE THAT FEW OTHER TRUCKS ON AUSTRALIAN ROADS CAN – AUSTRALIAN APPLICATION ENGINEERING.

Purpose-built to meet the specific requirements of its intended use, and equipped with advanced safety technology, each Kenworth is designed to operate with optimal protection for the driver, vehicle, payload and other road users.

On the new T410SAR, that protection includes safer cabin access. With a low cab floor height, it is equipped with wide opening cabin doors, inclined external steps and carefully positioned handles and grab rails, allowing drivers easier access and the ability to maintain three points of contact at all times.

The more intuitive dashboard design aids concentration and helps reduce fatigue, while the new sloping bonnet, provides fantastic forward vision. Re-positioned A-pillars, a larger windscreen, larger side windows and low-mounted anti-vibration side mirrors combine to create commanding views to the front, sides and rear.

Because some on-road dangers can't be foreseen, the T410SAR also offers the full suite of Kenworth Electronic Brake Safety Systems (EBSS).

Comprising Electronic Stability Control, incorporating Active Cruise Control with Braking, Collision Mitigation with Autonomous Emergency Braking and Lane Departure Warning, these proven technologies monitor road and traffic conditions constantly to prevent, and protect you from, potentially hazardous situations.

THE BEST OF INTEGRATION

POWERED BY THE PACCAR MX-13 ENGINE, THE T410SAR OFFERS A RANGE OF INTEGRATED TRANSMISSIONS, INCLUDING THE PACCAR 12-SPEED AUTOMATED TRANSMISSION – PURPOSE-BUILT TO WORK SEAMLESSLY WITH THE MX-13 ENGINE.

With optional horsepower and torque ratings up to 510 hp and 1850 lb-ft, the PACCAR MX-13 engine available in the T410SAR, combines maximum power with a flat torque curve for outstanding fuel efficiency and vehicle performance. The 12v MX-13 provides exceptional levels of refinement and service simplicity. No longer requiring 24v-12v inverters, the electrical architecture is even more simple, durable and cost-effective to service and maintain.

The T410SAR offers the operational advantages of either the PACCAR 12-speed or Eaton 18-speed automated transmissions; both options integrating with the PACCAR 12v MX-13 engine. Designed from the ground up, the PACCAR 12-speed transmission features an aluminium main case, internal sensors and wiring, and helical cut gearing. With a torque capacity of 1850 lb-ft and rated to 50 tonnes GCM, the 12-speed transmission is smoother and ticks all the boxes in terms of class-leading weight, durability and serviceability.

Like the PACCAR 12-speed transmission, the Eaton 18-speed UltraShift Plus automated manual transmission delivers the performance and reliability needed for years of trouble-free operation and is available with a torque capacity of 1850 lb-ft or 2050 lb-ft and a rating of up to 70 tonnes GCM.

For ease of control, both the PACCAR and Eaton automated transmissions are operated via a transmission stalk controller mounted on the right hand side of the steering column. The T410SAR also offers the option of an 18-speed Eaton manual transmission.



PACCAR 12-SPEED AUTOMATED TRANSMISSION

FLEXIBILITY AT ITS BEST

MAIN SPECIFICATIONS AND OPTIONS

| CONFIGURATION | T410SAR |
|--|----------|
| 6X4 | Standard |
| ENGINE | |
| PACCAR MX13 - 460 HP / 1700 LB-FT TORQUE | Standard |
| PACCAR MX13 - 510 HP / 1850 LB-FT TORQUE | Optional |
| EXHAUST | |
| EGP OUTSIDE RAIL RHR WITH GROUND DISCHARGE FOR MX | Standard |
| EGP OUTSIDE RAIL RHR, DUAL SIDE OF CAB EXHAUST | Optional |
| UREA | |
| 75L ADBLUE TANK WITH BATTERY BOX | Standard |
| 140L ADBLUE TANK | Optional |
| AIR CLEANER | |
| DONALDSON 2500 SERIES AIR CLEANER MOUNTED UNDER HOOD | Standard |
| TRANSMISSION – MANUAL | |
| EATON RTLO18918B 18 SPEED / 1850 LB-FT TORQUE | Optional |
| EATON RTLO 20918B 18 SPEED / 2050 LB-FT TORQUE | Optional |
| TRANSMISSION – AUTOMATED | |
| PACCAR AUTOMATED PO-18F112C 12 SPEED / 1850 LB-FT TORQUE | Standard |
| EATON FO-18E318A-MXP ULTRASHIFT PLUS 18 SPEED / 1850 LB-FT TORQUE | Optional |
| EATON FO-20E318A-MXP ULTRASHIFT PLUS 18 SPEED / 2050 LB-FT TORQUE | Optional |
| FRONT AXLE | |
| DANA E-14621 - 6.6T GAWR | Standard |
| MERITOR MFS66-122 - 6.6T GAWR | Optional |
| MERITOR MFS66-124 - 6.6T GAWR | Optional |
| MERITOR MFS73 - 7.3T GAWR | Optional |
| REAR AXLE | |
| DANA DSH40P - 18.1T GAWR | Standard |
| DANA D46-170 - 20.9T GAWR | Optional |
| MERITOR MT-20-14XG - 20.0T GAWR | Optional |
| MERITOR RT46-160GP - 20.9T GAWR | Optional |
| SAFETY SYSTEMS | |
| ABS – ANTILOCK BRAKING SYSTEM | Standard |
| DTC – DRAG TORQUE CONTROL | Standard |
| ATC – AUTOMATIC TRACTION CONTROL | Standard |
| HSA – HILLSTART ASSIST* | Optional |
| ACB – ACTIVE CRUISE BRAKING** | Optional |
| TRM – TRAILER RESPONSE MANAGEMENT | Optional |
| ESP – ELECTRONIC STABILITY PROGRAM | Optional |
| CMS – COLLISION MITIGATION WITH AEB** | Optional |
| LDW – LANE DEPARTURE WARNING** | Optional |
| * only available with PACCAR & Eaton Ultrashift PLUS Automated Transmissions | |
| ** as part of Integrated Active Safety Systems | |
| BRAKES | |
| DRUM | Standard |
| DISC | Optional |
| WHEELS | |
| ALCOA ALLOY 10 STUD | Standard |
| ALCOA ULTRA ONE ALLOY 10 STUD | Optional |
| ALCOA PACCAR / KENWORTH STYLE ALLOY 10 STUD | Optional |
| SLEEPER | |
| 600MM AERO ROOF | Optional |
| 600MM FLAT ROOF | Optional |
| 760MM MID ROOF | Optional |
| 860MM AERO ROOF | Optional |
| CAB ACCESS | |
| 2 STEP ROUND 625MM DIAMETER FUEL TANKS | Standard |
| 3 STEP RECTANGULAR FUEL TANKS | Optional |
| FUEL TANKS | |
| ROUND 625MM DIAMETER ALUMINIUM POLISHED TANKS | Standard |
| RECTANGULAR ALUMINIUM POLISHED TANKS | Optional |

DAY CAB 6X4

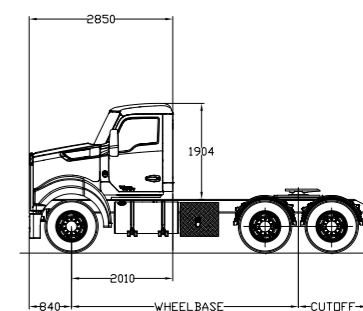

600MM FLAT ROOF SLEEPER

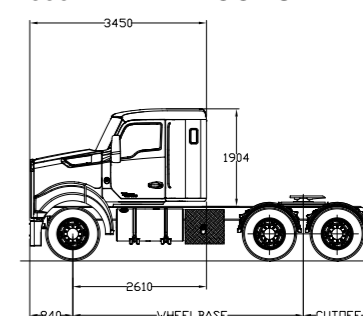

600MM AERO ROOF SLEEPER

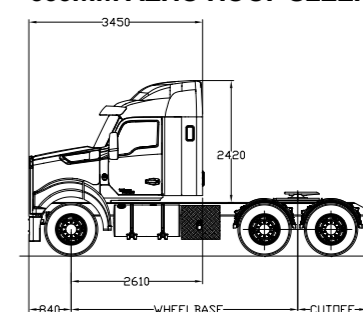

760MM MID ROOF SLEEPER

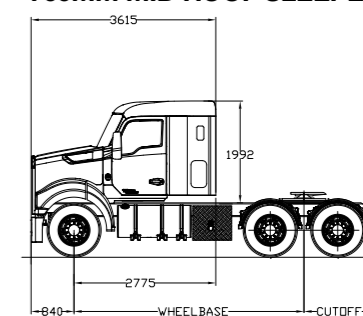

860MM AERO ROOF SLEEPER

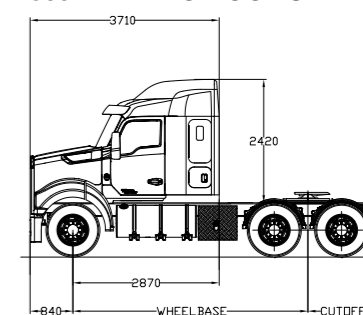

THE BEST SERVICE AND SUPPORT



OUR NETWORK OF DEALERSHIPS IN AUSTRALIA, NEW ZEALAND AND PAPUA NEW GUINEA ARE BEHIND YOU ALL THE WAY, SO YOU CAN HAVE ABSOLUTE CONFIDENCE FOR YOUR JOURNEY.

Comprising more than 50 regional and metropolitan locations, our long-established Australian network spans the country, helping to provide a seamless ownership experience.

Depending on location, customers can purchase their Kenworth, arrange finance through PACCAR Financial, and access servicing and parts, all from the one dealership. Or for a fully tailored leasing or rental solution, speak with PacLease.

PACCAR Assist—our dedicated 24/7 roadside assistance service—also provides Australia-wide coverage. One call to 1800 472 222 is all it takes to summon help from your nearest dealership.

For more information, contact your local Kenworth Dealer or visit www.kenworth.com.au



IMPORTANT: the vehicles shown in this brochure are for illustrative purposes only and may include some non-standard optional equipment. All weights and measurements should be regarded as approximate only. For full details contact your Kenworth Dealer. In the interests of product improvement, Kenworth reserves the right to change these specifications without prior notice.



AUSTRALIAN MADE. WORLD'S BEST.