

Reliability in Action

# L938H WHEEL LOADER

Operating Weight: 11,750kg  
Engine Power: 105kW / 141hp  
Bucket Capacity: 2.1m<sup>3</sup>





## Powerful, reliable & efficient

The SDLG L938H is powerful, robust, yet highly efficient and features a 4-speed power shift transmission for smoother shifting and greater speed capabilities. The L938H is the ideal machine for transporting and loading loose materials, general material handling, and construction work with an extensive range of attachments available for ultimate versatility and productivity.

### ULTIMATE RELIABILITY

The L938H chassis and loader frame have been structurally enhanced to improve service life, stability and productivity. The rear axle oscillates and has a greater load capacity for increased driving force in tough applications. The opening angle of the engine hood is also easily accessible with grouped filters for simplified maintenance.

### HIGHER EFFICIENCY

Featuring a high torque, fuel efficient Weichai Tier 3 engine, the L938H delivers powerful performance with superior reliability, and extended maintenance intervals for reduced running costs. Bucket profiles are also precisely matched with the loader's geometry to provide greater working efficiency.

### OPTIMISED HYDRAULICS

The hydraulic system has advanced sealing technology, combined with higher working pressures which increases efficiency and productivity. The L938H also features a responsive load sensing steering system and tropical cooling package for a reliable operating experience.

### POWERFUL & ROBUST

The combination of the Weichai engine, quality machine components, and SDLG's uniquely designed F4/R3 power shift transmission, enables ultimate durability and reliability in all applications for an improved machine service life.

### OPERATOR COMFORT

The H-Series cab is ergonomically designed with a curved front windscreen for better vision, more space, and improved sealing for greater comfort and reduced noise. Extra air vents also contribute to an enhanced operator experience, and the cab is ROPS/FOPS certified for safety.



# Main Parameter



## 50 YEARS OF RELIABILITY

SDLG is an internationally renowned brand spanning 130 countries, and over 50 years of equipment manufacturing expertise.



## MEMBER OF THE VOLVO GROUP SINCE 2007

SDLG machinery integrates the design influence and quality control standards of Volvo.



## 3 YEAR / 6,000 HOUR WARRANTY\*

Backed nationally by CJD Equipment's extensive branch and SDLG dealer network.

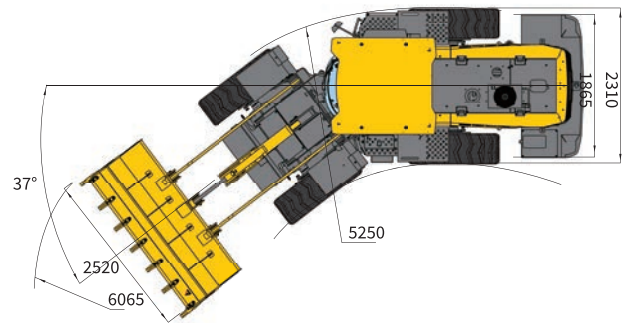
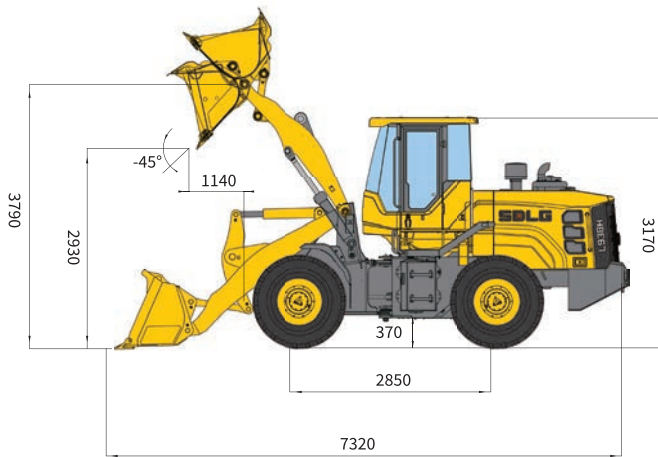

ITEM	SPECIFICATIONS
<b>OVERALL PARAMETER</b>	
Operating weight	11,750 kg
Rated load	3,000 kg
Length	7,320 mm
Width	2,520 mm
Height	3,170 mm
Bucket capacity	2.1 m <sup>3</sup>
Max. tractive force	100 kN
Max. breakout force	≥96 kN
Tipping load	≥70 kN
<b>ENGINE</b>	
Rated power @ speed (kW@r/min)	105 @ 2200
Maximum torque @ speed (Nm@r/min)	660 @ (1400-1600)
Emission standard	Tier III
<b>STEERING SYSTEM</b>	
System pressure	14 Mpa

ITEM	SPECIFICATIONS
<b>HYDRAULIC SYSTEM</b>	
System pressure	17.5 Mpa
Total cycle time (bucket lift & dump & fall)	≤ 9.2 s
<b>TRANSMISSION SYSTEM</b>	
Transmission type	Planetary power shift
Gears	F4 & R3
Speed	0-38 km/h
<b>FILL CAPACITY</b>	
Fuel	200 L
Hydraulic oil	128 L
Engine	18 L
Transmission	44 L
Drive axle	28 L + 28 L
Braking system	2 L

\*The right of final interpretation of the above mentioned parameters shall be reserved by SDLG. No further notice will be given in case of any change. Illustrations in the text may not always be the standard illustrations for this model.

# Equipment & Features

## STANDARD EQUIPMENT

### ENGINE

Weichai WP6G175E201 engine  
Air pre-filter  
Multi-stage fuel filter

SDLG transmission  
Tropical cooling package

### ELECTRICAL

Centralised fuses  
Back-up alarm  
3rd function connector

Work lights  
Rotating beacon

### UNDERCARRIAGE

SDLG enhanced axle  
17.5-25 tyre

### ATTACHMENTS

2.1m<sup>3</sup> GP bucket with BOCE  
Quick coupler

### CAB & INTERIOR

Single joystick pilot control  
Rocker switches  
Adjustable steering column  
Radio

ROPS/FOPS cabin  
Air conditioning / Heater  
Digital instrument display  
Suspension seat



## OPTIONAL EQUIPMENT

### ELECTRICAL

LED work lights

### ENGINE

Oil bath air filter  
Air intake pre-heating

### UNDERCARRIAGE

17.5-25-12pr block pattern tyre  
Tyre chain

17.5-R25 radial tyre  
License plate bracket

### CAB & INTERIOR

Rear view camera

### ATTACHMENTS

Log grapple **A**  
Pallet fork **C**  
Super long reach arm  
1.8m<sup>3</sup> - 3m<sup>3</sup> light material bucket **F**

Grass gripper **B**  
Crane arm **D**  
1.5m<sup>3</sup> - 1.8m<sup>3</sup> rock bucket **E**

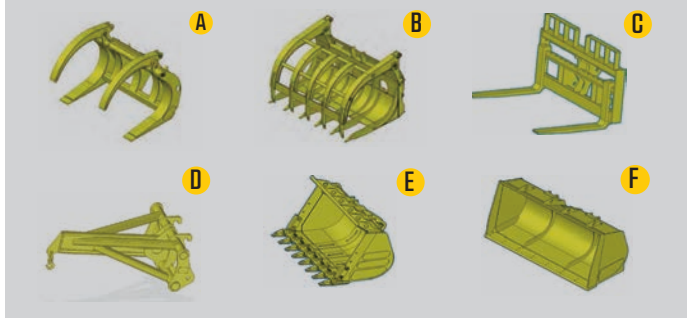

Founded in 1974, CJD Equipment is a privately-owned Australian company and leading provider of world class equipment and trucks. Offering a diverse range of products from iconic brands such as Volvo CE and SDLG, CJD's branch and SDLG dealer network spans the country, with 24/7 sales, parts and service support from over 600 highly experienced staff.

### Head Office

54 Great Eastern Highway  
South Guildford WA 6055

[enquiries@cjed.com.au](mailto:enquiries@cjed.com.au)

[cjed.com.au](http://cjed.com.au)

1300 139 804

Find us on socials

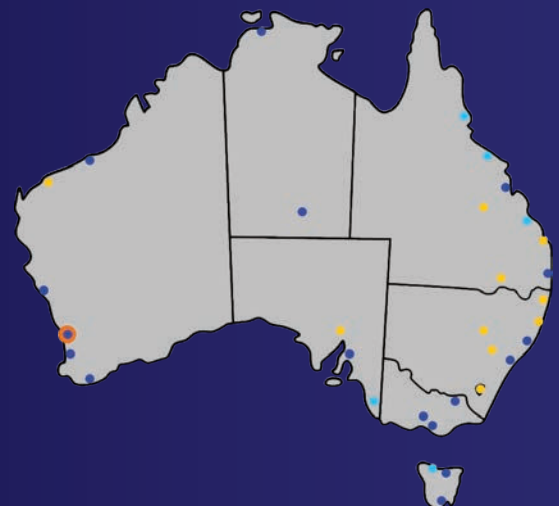

BIG ENOUGH TO TRUST SMALL ENOUGH TO CARE

SDLG L938H (09-2023)

Australian Version